

# XO-VAC-PLUS

Desktop Thermal Vacuum Chamber  
(-25C to 125C)



Low-cost, reliable, CubeSat  
compatible and outstanding  
payload connectivity

**Available Q3 2021**

EXOBOTICS

## PERFORMANCE SPECIFICATIONS

Vacuum range	10 <sup>-7</sup> mbar to 1 atm
Temperature range	-25 C to 125 C
Time to reach 1E-5 mbar	< 20 min
Time to vent	< 10 min (Auto-vent)
Heating power	up to 300 W
Cooling power	up to 150 W
Heating rates	up to 1.2 C/min
Cooling rates	up to 0.2 C/min
Time to reach 125 C	< 2 h (no payload)
Time to reach -25 C	< 8 h (no payload)
Temperature uniformity	< 1 C at equilibrium
Temperature accuracy	< 1 C
Temperature resolution	0.01 C

## MECHANICAL SPECIFICATIONS

External dimensions (H x W x D)	1250 x 600 x 750 mm (w/ rack)
Working volume	8.4 L
Payload tray	301 x 107 mm (3U Cubesat)
Door clearance	Dia. 197 mm
Total mass	approx. 65 kg
Noise level at 1 m	< 62 dB
Power consumption	< 1 kW, 400 W typical
Electrical input	230 V AC 50/60 Hz
Software interface	via USB

## ENVIRONMENTAL SPECIFICATIONS

Operating Temperature	18 - 21 C (AC recommended)
Operating Humidity	Up to 95%, non-condensing
Maximum elevation	3000 m
Environment	Indoor

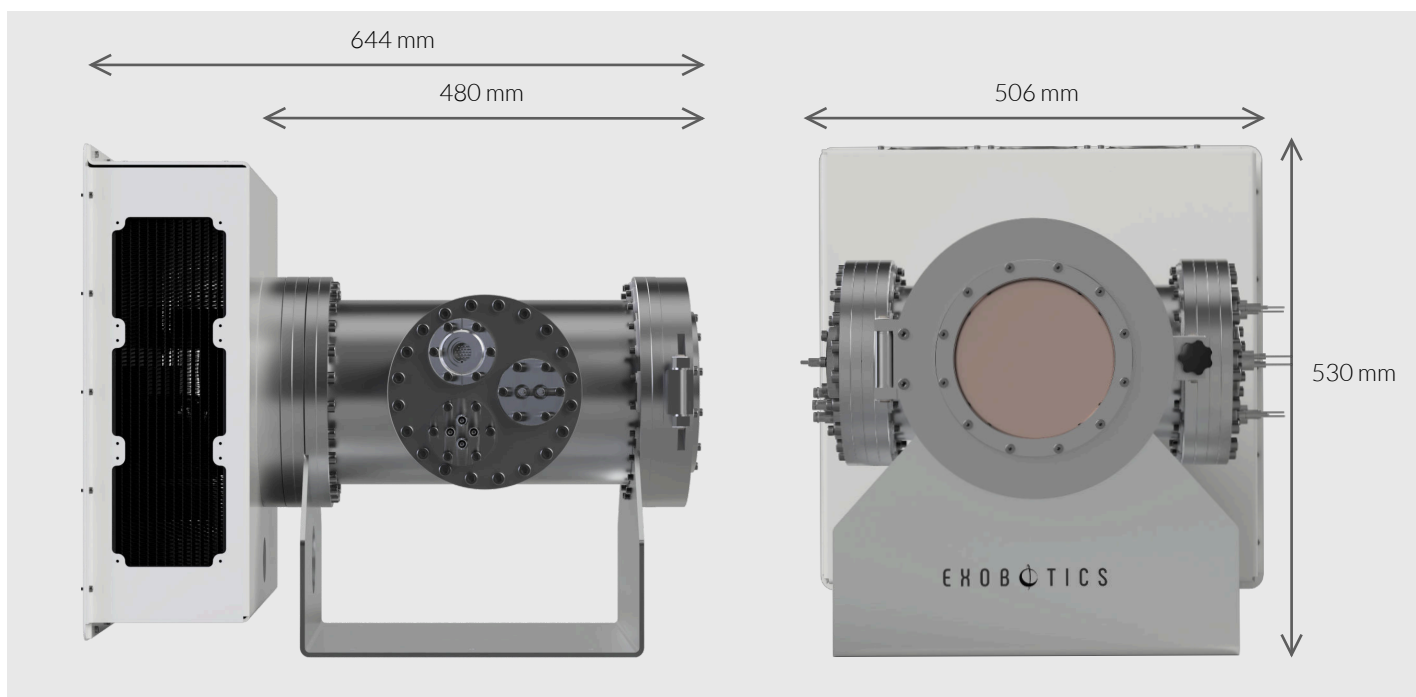

## ABOUT XO-VAC-PLUS

XO-VAC is a low-cost, portable thermal vacuum (TVAC) testing system which simulates the extreme environmental conditions of space by exposing payloads to high vacuum at high or low temperatures. This all-in-one 'desktop' TVAC solution is price competitive with renting typical TVAC facilities, and is focused on enabling high throughput, on-demand TVAC testing for industry and academia. XO-VAC uniquely enables customers to run TVAC testing throughout product lifecycles. XO-VAC USP: 1) The only low cost, portable, compact, low maintenance, all-in-one TVAC

solution on the market. 2) XO-VAC is your very own personal test facility, enabling rapid iterations throughout project lifecycles, cutting out waiting time and cost of facilities, and reducing R&D cost and time. 3) A customer-oriented solution where customisation is offered as standard. More information is available on our website at: <https://exobotics.space/xo-vac/>

EXO BOTICS



## EXOBOTICS (XOB)

Exobotics (XOB) is a Cambridge & Cornwall based company specialising in small-satellites and robotics. Our goal is to lower barriers to entry in terms of cost, skill, and time required to explore space, making the Moon and beyond as accessible and economical as low-Earth orbit. With our 'Customisation as Standard' principle, our satellite subsystems and ground support equipment is optimised for customer needs with in-house thermal vacuum, vibration, and shock testing capability.